

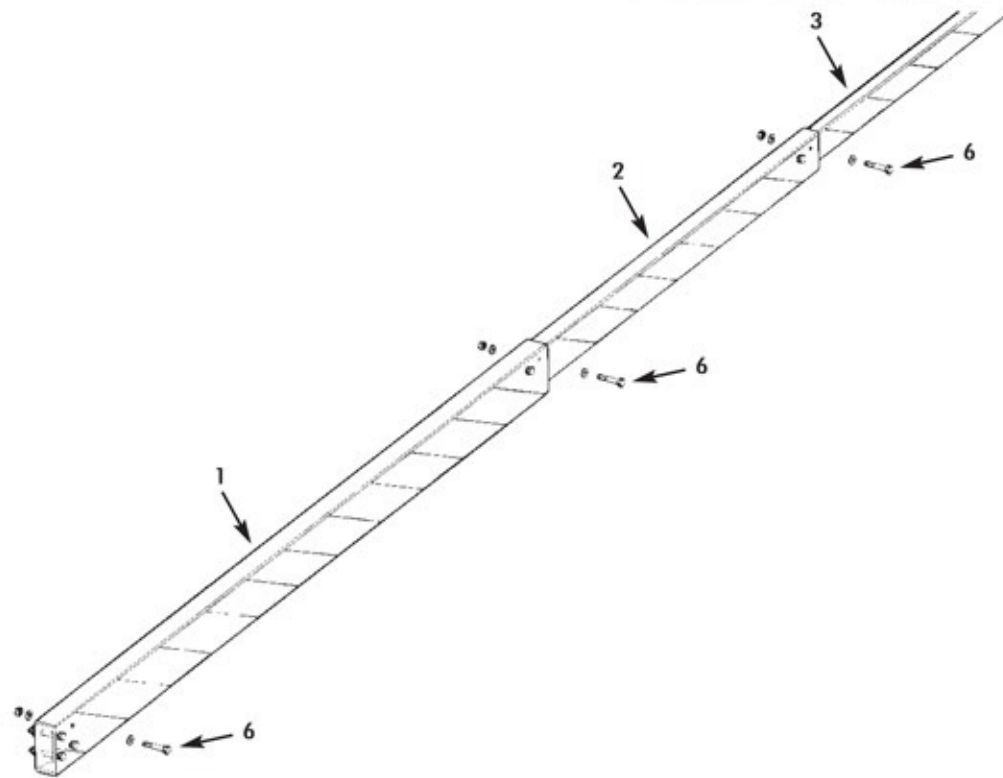

High Wind Profile—Fiberglass—Alumi-Glass®— Alumi-Lite® Gate Arms



High Wind Profile Gate Arms

ALUMI-LITE HIGH WIND PROFILE GATE – utilizes aluminum for every section of the gate		
Length Range	Description	NEG Number
8' – 40'	Alumi-Lite High Wind Profile Gate	NEG-8007A-#
8', 16', 21', 24'	High Wind Profile Aluminum 1st Section	NEG-3130-#
4' – 16'	High Wind Profile Aluminum 2nd Section	NEG-1WCA502-#
4' – 16'	High Wind Profile Aluminum 3rd Section	NEG-1WCA503-#
ALUMI-GLASS HIGH WIND PROFILE GATE – utilizes an aluminum 1st section, a fiberglass 2nd section, and a fiberglass 3rd section		
Length Range	Description	NEG Number
8' – 40'	Alumi-Glass High Wind Profile Gate	NEG-8007-#
8', 16', 21', 24'	High Wind Profile Aluminum 1st Section	NEG-3130-#
4' – 16'	Fiberglass High Wind Profile Aluminum 2nd Section	NEG-1WC502-#
4' – 16'	Fiberglass High Wind Profile Aluminum 3rd Section	NEG-1WC503-#
FIBERGLASS HIGH WIND PROFILE GATE – utilizes fiberglass for all sections of the gate		
Length Range	Description	NEG Number
8' – 40'	Fiberglass High Wind Profile Gate	NEG-8006-#
8', 16', 21', 24'	Fiberglass High Wind Profile 1st Section	NEG-1WC501-#
4' – 16'	Fiberglass High Wind Profile 2nd Section	NEG-1WC502-#
4' – 16'	Fiberglass High Wind Profile 3rd Section	NEG-1WC503-#
A. Insert desired length where the "#" appears in the above part numbers.		